

# The future of telematics from a **customer** perspective

Intermodal Europe  
11<sup>th</sup> October 2023

**Joel undir Leitinum**





# Joel undir Leitinum

MsC Economics, Copenhagen Business School

2021-2023

- **Chairman Globe Tracker**

2021-2023

- **Board Globe Tracker**

2021-2023

- **CEO Postverk Foroya**

Turnaround and expanding into other markets

- **Board member and Co-founder Nemlia**

Care/elder tech going into markets DE, DK, NL, FR, UK

- **Held other director positions etc.**

# Define customer ...

The future of telematics from a customer perspective

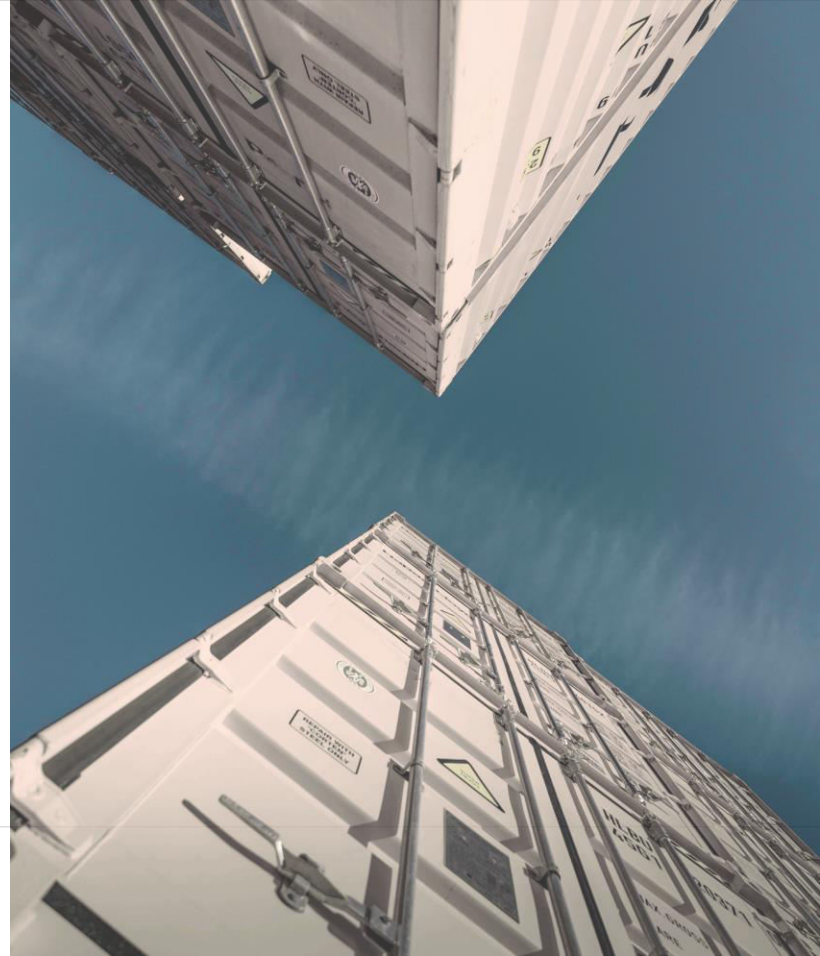

# Traceability

## The salmon industry in 2000

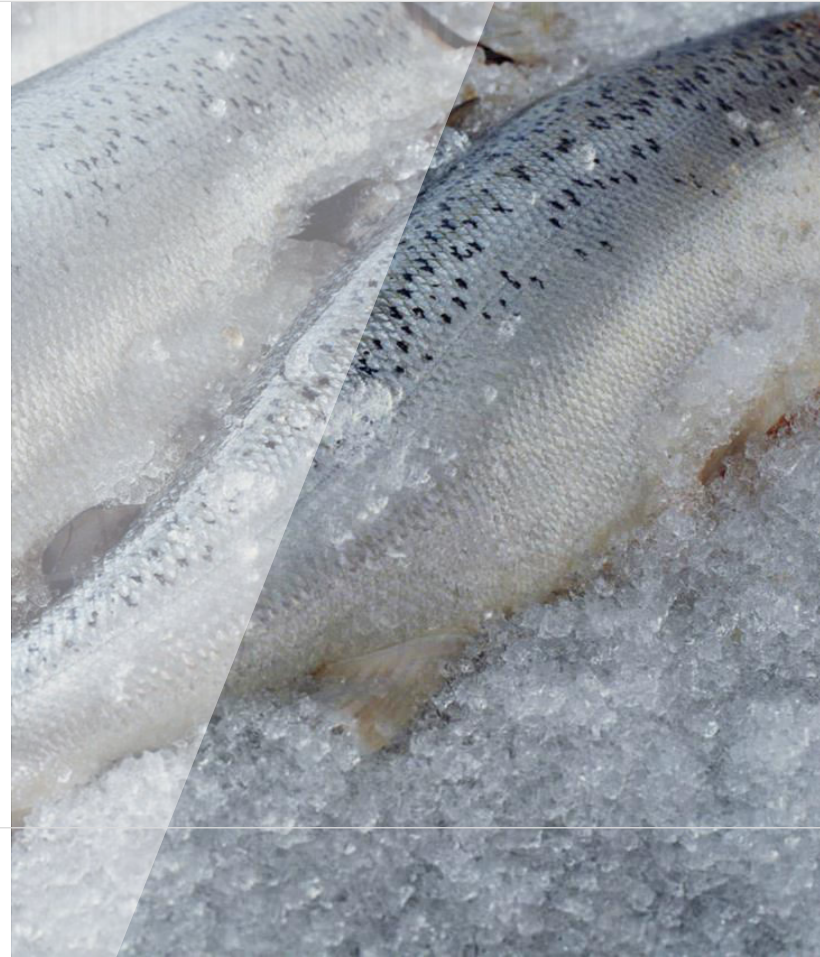

# Where is my cargo?

The future of telematics from a customer perspective

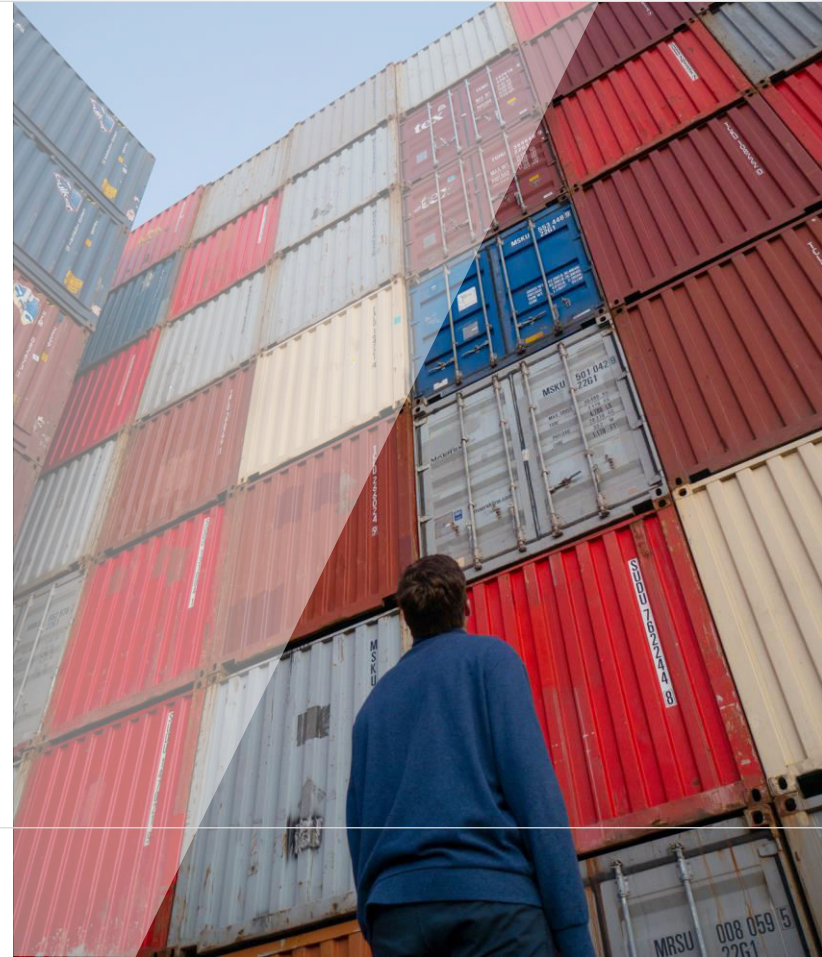

# The 'trad' way

- Scanning?
- RFID?
- Loads of notifications - but not live...?





# Level of 'tracking'

- Container / Chassis / Trailer / Rail ...
- Pallets
- Parcels
- Items

# From BIG data to **HUGE** data





# Remote monitoring

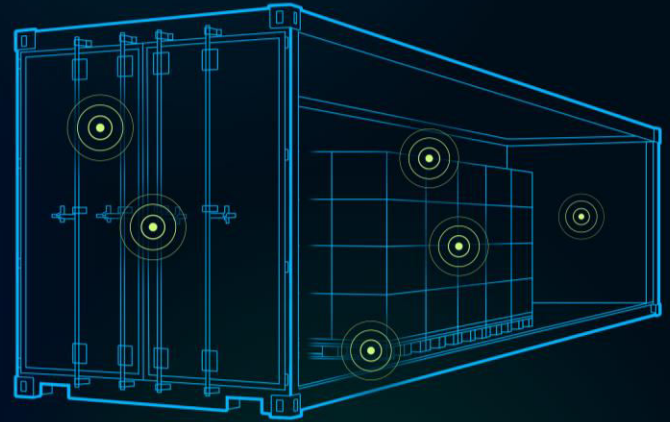

# Pseudo work

The future of telematics from a customer perspective

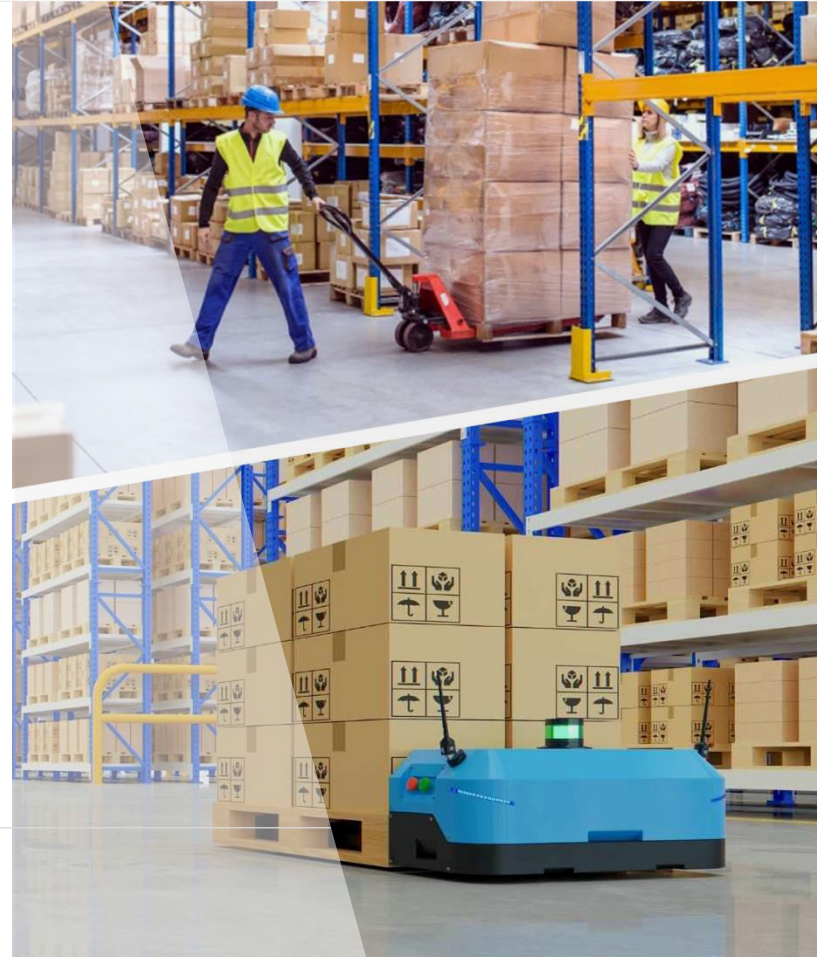

**Thank  
you**